



Maya Sanchez
Mayor

Leticia Miranda
Alderson Place 1

David Cantu
Alderson Place 2

Miguel Najera Jr.
Alderson Place 3

Rebecca Martinez-Juarez
Alderson Place 4

George Almanzar
Alderson Place 5

CITY OF SAN ELIZARIO

ORDINANCE NO. 1715.12

LIGHTING ORDINANCE

AN ORDINANCE ENACTING REGULATIONS FOR OUTDOOR LIGHTING (DARK SKIES) AND PROVIDING FOR THE FOLLOWING: RULES; STANDARDS; PROCEDURES; CRIMINAL PENALTIES NOT TO EXCEED \$500 AND CIVIL FINES OF UP TO \$1000 PER VIOLATION; AND EFFECTIVE DATE.

WHEREAS, the City Council of the City of San Elizario (“City Council”) seeks to provide for the regulation of lighting within the city limits of the City of San Elizario, Texas (“City”), and where applicable, in the extraterritorial jurisdiction (ETJ); and

WHEREAS, the City Council seeks to maintain the value of San Elizario’s scenic beauty and rural charm through comprehensive regulations and restrictions on lighting; and

WHEREAS, the City Council finds that unnecessary and improperly designed light fixtures cause glare, light pollution and wasted resources which can result in hazardous conditions for all modes of transportation, the diminishing ability to view the night sky, light trespass, and an unattractive townscape; and

WHEREAS, the people who live in and near the City value the natural environment, including the beauty of the area and high quality of the night sky; and

WHEREAS, the City desires to protect the health, safety and welfare of the general public, and to protect the night sky that adds to the quality of life and economic well-being of the City and lighting regulations will not sacrifice the safety of our citizens or visitors, or the security of property; and

WHEREAS, pursuant to Texas Local Government Code Chapter 217, the City has specific authority to adopt an ordinance or police regulation declaring, prohibiting and abating public nuisances; and

WHEREAS, pursuant to Texas Local Government Code Chapters 211 and 214, the City has general authority to adopt an ordinance or police regulation regarding the use of land, improvements upon land, and construction or building upon land; and

WHEREAS, pursuant to Texas Local Government Code Section 51.001, the City has general authority to adopt an ordinance or police regulation that is for the good government, peace or order of the City and is necessary or proper for carrying out a power granted by law to the City; and

NOW, THEREFORE, BE IT ORDAINED by the City Council of the City of San Elizario:
ORDINANCE I. FINDINGS OF FACT

The foregoing recitals are adopted as facts and incorporated fully herein.

ORDINANCE II. ADOPTION AND ENACTMENT

The City of San Elizario hereby adopts the "City of San Elizario Outdoor Lighting Ordinance", to be known also as the "Dark Sky Ordinance", attached hereto as *Attachment A*, and incorporated fully herein for all intents and purposes.

ORDINANCE III. REPEALER AND SEVERABILITY

REPEALER: All ordinances, or parts thereof, that are in conflict or inconsistent with any provision of this Ordinance are hereby repealed to the extent of such conflict, and the provisions of this Ordinance shall be and remain controlling as to the matters regulated, herein.

SEVERABILITY: Should any of the clauses, sentences, paragraphs, sections or parts of this Ordinance be deemed invalid, unconstitutional, or unenforceable by a court of law or administrative agency with jurisdiction over the matter, such action shall not be construed to affect any other valid portion of this Ordinance.

ORDINANCE IV. EFFECTIVE DATE

This Ordinance shall be effective immediately upon passage and publication in the city's official newspaper.

PASSED AND APPROVED this, the 8th day of August, 2017 by a vote of 5 (ayes) to 0 (nays) to 0 (abstentions) of the City Council of San Elizario, Texas.

CITY OF SAN ELIZARIO, TEXAS



Maya Sanchez, Mayor

Attachment A

**CITY OF SAN ELIZARIO
LIGHTING (DARK SKY) ORDINANCE**

Section 1. Title

This Ordinance shall be known as the “Dark Sky Ordinance”.

Section 2. Definitions

Words and phrases used in this Ordinance shall have the meanings set forth in this section. Terms that are not defined below, but are defined elsewhere in the Code of Ordinances, shall be given the meanings set forth in the Code. Words and phrases not defined in the Code of Ordinances shall be given their common, ordinary meaning unless the context clearly requires otherwise. When not inconsistent with the context, words used in the present tense shall include the future tense; words in the plural number shall include the singular number (and *vice versa*); and words in the masculine gender shall include the feminine gender (and *vice versa*). The word "shall" is always mandatory, while the word "may" is merely directory. Headings and captions are for reference purposes only.

Addition: enlargement of the building’s gross floor area, seating capacity, or parking spaces, either with a single construction project or cumulative series of construction projects, after the enactment of this Ordinance.

Applicant: a person or entity who submits to the City an application for an approval required by City Ordinances. The term does not include anyone other than the Property Owner(s), tenant(s), or a duly authorized agent and representative of the Property Owner. As to enforcement, the Property Owner(s) shall have ultimate liability for violations of this Ordinance.

City: the City of San Elizario.

City Building Inspector: the City Building Official or designees of the Building Official, Mayor or City Administrator to responsible for inspections or enforcement of the City Building Codes and/or this Ordinance.

City Limits: the incorporated municipal boundary of the City, as may be expanded by annexation.

ETJ: the extraterritorial jurisdiction of the City.

Full Cut-off Fixtures: fixtures, as installed, that are designed or shielded in such a manner that all light rays emitted by the fixture, either directly from the lamps or indirectly from the fixture, are projected below a horizontal plane running through the lowest point on the fixture where light is emitted.

Holiday Lighting: lighting used for a specific celebration which may be one of the following types:

- (1) Festoon type low-output lamps, limited to small individual bulbs on a string.
- (2) Low-output lamps used to internally illuminate yard art.
- (3) Flood or spot lights producing less than 2000 lumens each, whose light source is not visible from any other property, and which are used only as temporary lighting.

Lighting: any source of light that does not include natural light emitted from celestial objects or fire. The term includes any type of lighting, fixed or movable, designed or used for outdoor illumination of buildings or homes, including lighting for billboards, streetlights, canopies, gasoline station islands, searchlights used for advertising purposes, externally or internally illuminated on- or off-premises advertising signs, and area-type lighting. The term includes luminous elements or lighting attached to structures, poles, the earth, or any other location.

Light Trespass: light emitted from fixtures designed or installed in a manner that unreasonably causes light to fall on a property other than the one where the light is installed, in a motor vehicle driver's eyes, or upwards toward the sky.

Logo: a representation or symbol adopted by a business, organization, or an individual used to promote instant public recognition.

Luminous Elements (of a Light Fixture): the lamp (light bulb), any diffusing elements, and surfaces intended to reflect or refract light emitted from the lamp individually or collectively comprise the luminous elements of a light fixture (luminaire).

Non-Residential: property designated as Non-Residential under the City's Zoning Ordinance.

Outdoor Lighting: temporary or permanent lighting that is installed, located or used in such a manner to cause light rays to shine outdoors. Non-residential fixtures that are installed indoors that cause light to shine outside are considered outdoor lighting under this Ordinance (depicted in Figure A, following). Residential fixtures installed indoors that cause light to shine outside are also considered outdoor lighting.

Figure A.

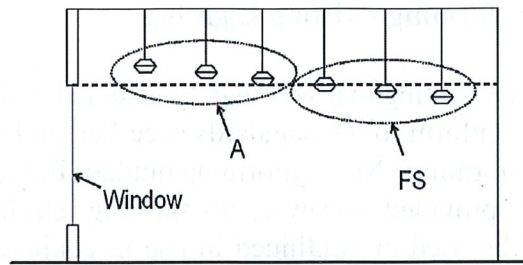

Elevation view showing a non-residential application of indoor lighting, labeled FS, subject to this ordinance, and indoor lighting, labeled A, installed and not subject to this Ordinance.

Person: a human individual, corporation, agency, unincorporated association, partnership, or sole proprietorship.

Residential: property designated as Residential under the City's Zoning Ordinance.

Temporary Lighting: lighting intended for uses which by their nature are of limited duration such as holiday decorations, civic events, or construction projects.

Uplighting: lighting that is directed in such a manner as to shine light rays above the horizontal plane.

Section 3. General

- (a) This Ordinance applies within the City Limits.
- (b) The City may apply this Ordinance to the ETJ through agreements with property owners of tracts in the ETJ.

Section 4. New Lighting

- (a) General. All outdoor lighting shall be installed in conformance with the provisions of this Ordinance, applicable Electrical Codes, Energy Codes, and Building Codes.
- (b) Non-Residential. All outdoor lighting installed on Non-Residential properties shall conform to the standards by this Ordinance.
- (c) Residential. All outdoor lighting installed on Residential properties shall comply with Sections 6(c), 9 and 10 of this Ordinance, and all other outdoor lighting installed on Residential properties that is affixed to a construction project for which a building permit or is an installation for which an electrical permit is required under City Ordinances and building codes shall conform to the standards established by this Ordinance.

Section 5. Nonconforming Existing Lighting

- (a) All existing outdoor lighting that was legally installed before the enactment of this Ordinance and that does not conform to the standards specified and imposed by this Ordinance shall be considered nonconforming. Nonconforming outdoor lighting is allowed to remain and be used until replacement, provided however, no flashing, strobing or intermittent lights or other illumination shall be used or continued in use in conjunction with the outdoor lighting and operations of a business on and after the effective date of this Ordinance unless allowed under Section 7 of this Ordinance or the City’s Sign Ordinance.
- (b) If more than fifty percent (50%) of the total value of a lighting structure has been destroyed, the nonconforming status expires and the structure’s previously nonconforming outdoor lighting is removed. Replacement lighting is allowed only in accordance with the standards of this Ordinance.
- (c) Nonconforming outdoor lighting shall be brought into conformance with this Ordinance as follows:
 - (1) Non-Residential Addition or Remodel. All existing outdoor lighting located on a subject property that is part of an application for a building permit for remodeling or the construction of an Addition is required to be brought into conformance with this Ordinance when the lighting is located on the part of the structure or property that is being remodeled or constructed before final inspection or issuance of a Certificate of Occupancy, as applicable.
 - (2) Residential Addition or Remodel. Nothing herein shall be construed to terminate a residential property’s nonconforming status as a result of an addition or remodel.

Section 6. Shielding

- (a) All outdoor lighting, except government owned light fixtures and lighting for public and private roadways, shall be shielded so that the luminous elements of the fixture are not visible from any other property. See Figures B and C.

Figure B.

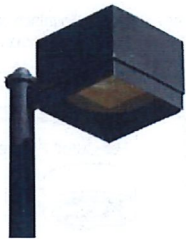

Mounting height or proximity to property lines may cause the luminous elements of a light fixture to need additional shielding, such as the examples pictured here.

Figure C.

DO NOT USE

MAY BE USED IN MOST CASES

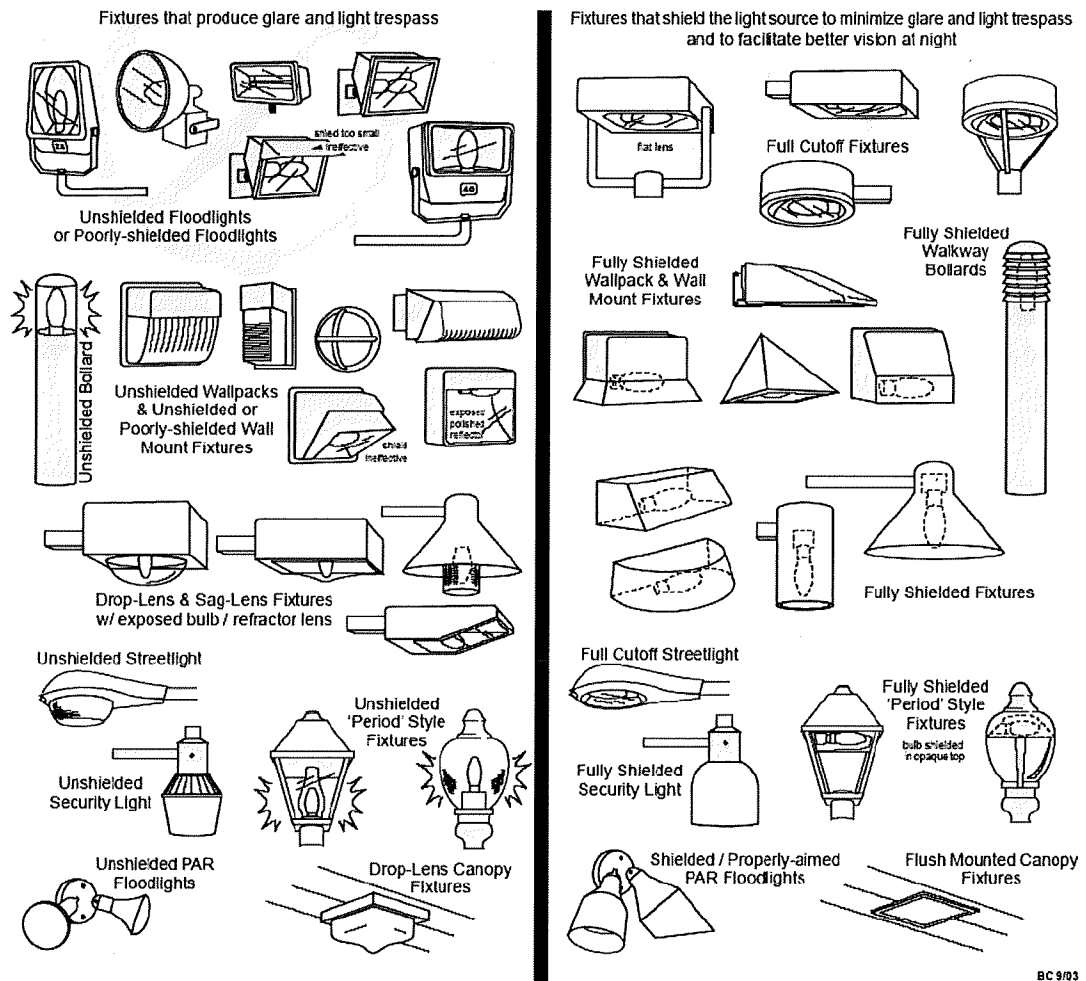

The lights on the left are non-conforming. Those on the right can be used in most cases. Depending on the mounting height and proximity to the property line, additional shielding may be necessary to prevent the luminous elements from being visible from any other property.

(b) Lighting for public and private roadways shall meet the qualifications to be full cut-off fixtures in order to limit light trespass. See Figure D below.

Figure D.

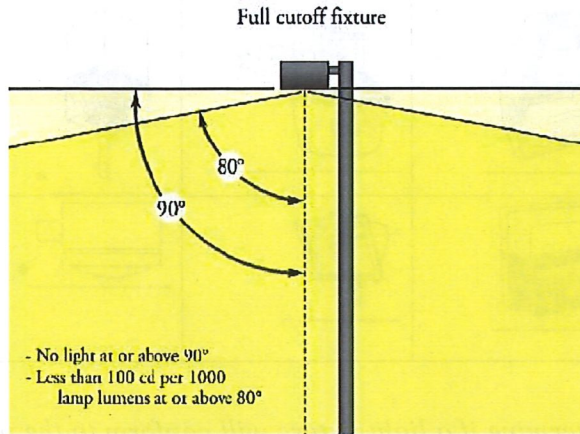

Full cutoff fixtures do not allow any light to be emitted above the fixture. The fixture controls glare by limiting the light output at 10 degrees below the horizontal.

- (c) Outdoor uplighting is prohibited, except in cases where the fixture is shielded by a roof overhang or similar structural shield.
- (d) Outdoor lighting fixtures, except uplighting covered in Section 6, subsection (c) above, are not allowed to have light escape above a horizontal plane running through the lowest point of the luminous elements. See Figures E and F, following.

Figure E.

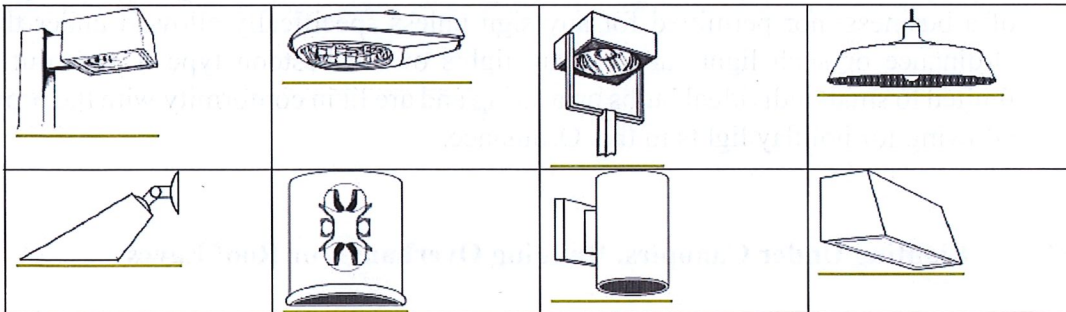

This figure shows examples of fixtures that will conform to the provision to not allow light to escape above a horizontal plane running through the lowest point of the luminous elements if they are closed on top and mounted such that the bottom opening is horizontal. Note that the mounting height and proximity to the property line may cause them to need additional shielding to prevent the luminous elements from being visible from any other property.

Figure F.

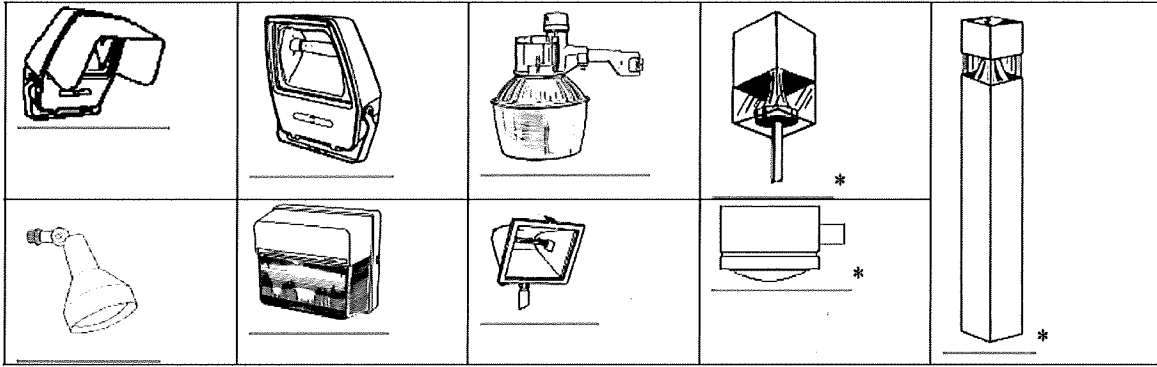

*A practical way to determine if a light fixture will conform to the provision to not allow light to escape above a horizontal plane running through the lowest point of the luminous elements: the lamp or tube, any reflective surface or lens cover (clear or prismatic) must NOT be visible when viewed from above or the side. This figure illustrates examples of fixtures that do NOT conform to the provision to not allow light to escape above a horizontal plane running through the lowest point of the luminous elements. *Note: Even though the lamps in these fixtures are shielded from direct view when viewed from the side or above, reflective surfaces within the fixtures and or lens covers are directly visible from the side.*

Section 7. Lighting for Outdoor Signs and Panels; Business Lighting and Operations

- (1) Outdoor externally-illuminated signs shall conform to all provisions of this Ordinance and the City's Sign Ordinance. No flashing, strobing or intermittent lights or other illumination shall be permitted in conjunction with the outdoor lighting and operations of a business, nor permitted for any sign unless specifically allowed under the Sign Ordinance or such lights are holiday lights of the Festoon type low-output lamps, limited to small individual bulbs on a string and are lit in conformity with the provisions allowing for holiday lights in this Ordinance.

Section 8. Lighting Under Canopies, Building Overhangs, or Roof Eaves

- (a) All Outdoor light fixtures located under canopies, under building overhangs, or under roof eaves must conform to all provisions of this Ordinance.
- (b) The center of the lamp or luminaire of outdoor light fixtures located under canopies, under building overhangs, or under roof eaves shall be located at five feet (5'), but no less than ten feet (10') from the nearest edge of the canopy or overhang as depicted in Figures G and H following:

Figure G.

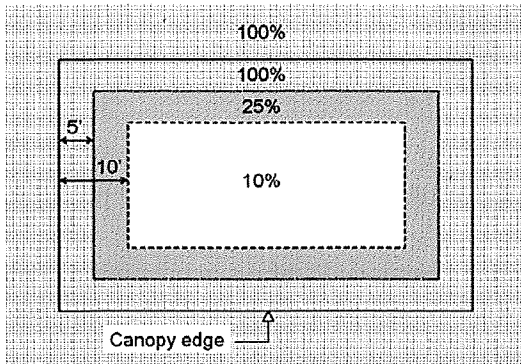

Plan view of a canopy, showing fixture location and initial lamp output percentage.
fixture location and initial lamp output

Figure H.

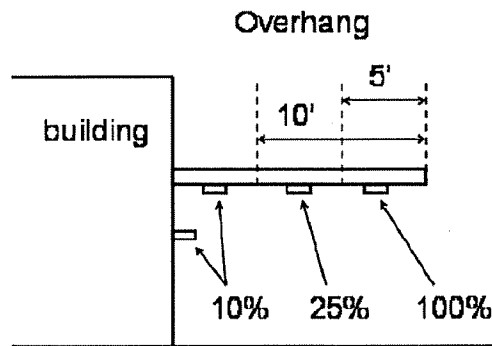

Elevation view of a canopy or overhang attached to a building, showing shielded percentage.

- (c) Lighting from outdoor light fixtures located under canopies, under building overhangs, or under roof eaves where the center of the lamp or luminaire is located ten (10) or more feet from the nearest edge of a canopy, building overhang, or eave shall not break the horizontal plane and shall be shielded as per Section 6(a).

Section 9. Flag Poles

Lighting of government flags on up to two (2) flag poles per property is permitted with the following restrictions:

- (1) Flag poles illuminated from below are limited to a height of twenty-five feet (25') above ground level. They are to be illuminated with a single spot type fixture mounted so that the lens is perpendicular to the flag pole.
- (2) Flag poles illuminated from above may utilize a light fixture attached to the top of the flag pole or a fixture mounted above the top of the flag pole on a structure within fifteen feet (15') of the flag pole and must comply with Section 6, subsections (a) and (b), except for lights such as the ones as shown in Figure I.

Figure I.

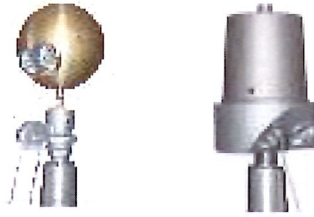

Section 10. Lighting Prohibitions

- (a) The installation of any mercury vapor fixture or lamp for use as outdoor lighting is prohibited.
- (b) The installation of any wall pack style fixture for use as outdoor lighting is prohibited unless the fixture is rated by the manufacturer as full cut-off. Examples of acceptable wall packs, when mounted with light directed downward only are shown in Figure J.

Figure J.



Examples of acceptable wall packs.

- (c) The installation of any barn-light style fixture for use as outdoor lighting is prohibited unless the fixture includes a full opaque reflector instead of the standard translucent lens. An example of barn-light style with and without the required opaque reflector is shown in Figure K, following.

Figure K.



Acceptable shielding of barn-style light fixtures.

- (d) The operation of searchlights, except by law enforcement or emergency responders, is prohibited.

Section 11. Submission of Plans and Evidence of Compliance

- (a) All commercial building permit applications must include an outdoor lighting plan which includes the following information:
 - (1) The location of all existing and proposed light fixtures (may be included on site plan).
 - (2) Specification sheets for all existing and proposed light fixtures.
 - (3) Acknowledgement that the Applicant has received notification of this Ordinance.
- (b) Upon receipt of residential building permit applications, City Staff shall provide the home builder and/or Applicant with educational materials about this Ordinance. The City's submission of educational materials shall be *prima facie* evidence that the Applicant has received notification of the provisions of this Ordinance.
- (c) Verification that a residential or commercial construction project requiring a building permit application has complied with the provisions of this Ordinance shall occur during the final electrical inspection by the City Building Inspector.

Section 12. Exemptions

The following lighting instances are exempt from this Ordinance:

- (1) Outdoor lighting for which light is produced directly by the combustion of fossil fuels.
- (2) Holiday lights.
- (3) Lighting required by law to be installed on motor vehicles.
- (4) Lighting needed during activities of law enforcement, fire and other emergency services.
- (5) Lighting employed during emergency repairs of roads and utilities may be unshielded provided the lights are positioned so they do not shine in the eyes of passing drivers.
- (6) Lighting required for the safe operation of aircraft.
- (7) Temporary lighting required to save life or property from imminent peril provided the lights are positioned so they do not shine in the eyes of passing drivers.
- (8) Lighting required by federal or state laws or regulations.

Section 13. Materials and Methods of Installation

This Ordinance is not intended to prohibit the use of any design, material or method of prescribed installation not specifically proscribed by this Ordinance, provided such alternative meets the legislative intent of this Ordinance.

Section 14. Administrative Guidance

The City is authorized to promulgate one or more interpretive documents to aid in the administration of, and compliance with, this Ordinance. Such interpretive documents shall be educational only and shall not constitute regulations, amendments, or exceptions.

Section 15. Enforcement

- (a) In case any lighting fixture or structure is erected, constructed or reconstructed, altered, repaired or converted is found to be in violation of this ordinance, the Building Inspector or designated city official shall institute any appropriate action to put an end to such violation.
- (b) Right of Entry. Upon presentation of proper credentials at the request of the land occupier or owner, the Building Inspector or designated city official may enter upon any property, vacant lots, or premises in the City to perform any duty imposed by this Ordinance.
- (c) Stop Work. The Building Inspector or designated city official may issue a Stop Work Order to immediately halt work on a property that is in violation of this Ordinance. Such order may permit limited work to occur that is necessary to stabilize and secure the site.
- (d) Notice of Violation.
 - (1) If the Building Inspector or designated city official has reason to believe that any of the provisions of this Ordinance are being violated, he/she shall provide or send a written Notice of Violation to the person responsible for such violation(s). Such notice shall state the nature of the violation(s) and provide a thirty (30) day grace period to correct the violation(s).
 - (2) Notice of violation shall be given by certified mail addressed to the owner at the owner's address as recorded in the appraisal district records of the appraisal district in which the property is located. A notice returned "refused" or "unclaimed" does not affect the validity of the notice and notice is considered delivered.
- (e) If at the end of the 30 day grace period the violation has not, in the judgment of the Building Inspector or designated city official, been satisfactorily corrected, then civil and/or criminal penalties and other remedies available by law shall be sought.

Section 16. Violation

- (a) It shall be unlawful for a person to locate, erect, construct, reconstruct, enlarge, change, maintain, or use any light structure or fixture in violation of this Ordinance.
- (b) It shall be unlawful for a person to emit light onto the property of another unreasonably interfering with the neighboring property owner's use and enjoyment of their property.
- (b) It is an offense to:
 - (1) install outdoor lighting in violation of this Ordinance;
 - (2) display or illuminate outdoor lighting in violation of this Ordinance; and
 - (3) fail to comply with any terms or conditions set forth in a permit issued under this Ordinance.
- (c) It is unlawful to expand, repair or replace outdoor lighting that was previously nonconforming, but for which the prior nonconforming status has expired, been forfeited, or otherwise abandoned.
- (d) Any violation of this Ordinance is hereby declared to be a nuisance.
- (e) An offense under this Ordinance is a misdemeanor.

Section 17. Penalties

- (a) Civil and criminal penalties. Any person violating this ordinance is subject to suit for injunctive relief as well as prosecution for civil and criminal violations.
 - (1) Criminal prosecution. Any person violating any provision of this ordinance shall, upon conviction, be fined a sum not exceeding \$500. Each day that a provision of this ordinance is violated shall constitute a separate offense.
 - (2) Civil remedies. Nothing in this ordinance shall be construed as a waiver of the city's right to bring a civil action to enforce the provisions of this Ordinance, and to seek remedies as allowed by law, including, but not limited to the following:
 - (A) Injunctive relief to prevent specific conduct that violates this Ordinance or to require specific conduct that is necessary for compliance with the ordinance; and
 - (B) A civil penalty of up to \$500 a day or, up to \$1,000.00 a day when it is shown that the defendant was actually notified of the provisions of this Ordinance and after receiving notice committed acts in violation of this Ordinance or failed to take action necessary for compliance with the ordinance. Each day constitutes a separate offense and separate violation; and
 - (C) Other available relief.

(b) Costs for Suit and Enforcement. In any civil action commenced by the City under this Ordinance, the City shall be entitled to recover from the defendant reasonable attorney's fees, costs of suit, and any other costs of enforcement, including but not limited to, inspection costs.